

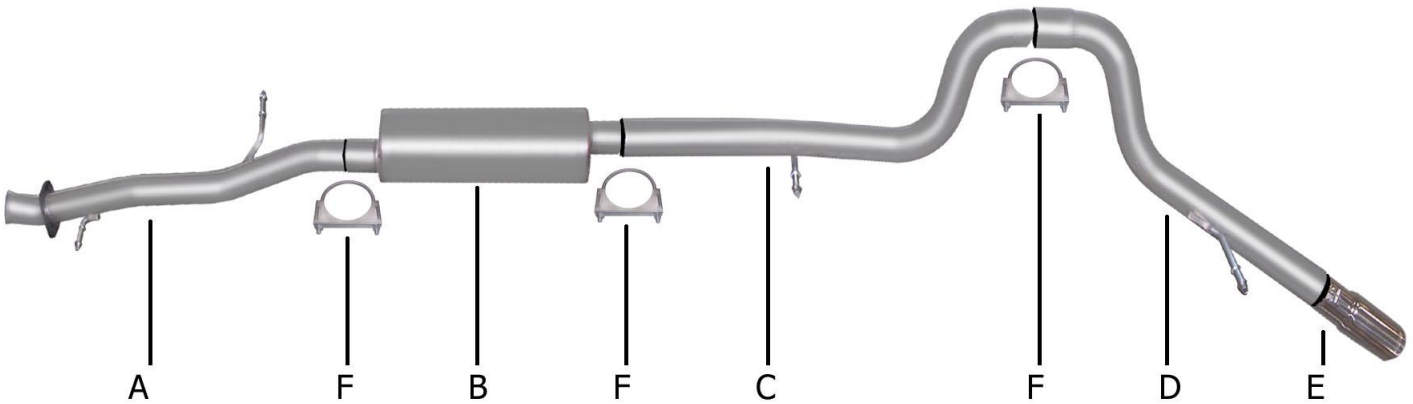

INSTALLATION INSTRUCTIONS
CAT BACK STAINLESS SINGLE EXHAUST
FORD EXPLORER SPORT TRAC 4.0L 4WD
CREW CAB 4DR
PART #619897



ITEM	PART #	QUANTITY	DESCRIPTION
A	1080-700856S	1	2½" Stainless Headpipe w/welded hanger and GP-110 flange
B	788200S	1	Stainless Superflow muffler
C	1081-700857S	1	2½" Stainless Tailpipe w/welded hanger
D	1082-700858S	1	2½" Stainless Exit pipe w/welded hanger
E	500374	1	3½" Stainless tip
F	5757	3	2½" Clamp

Thank you for purchasing our Gibson exhaust system for your vehicle. If you need further assistance, please do not hesitate to call our technical dept at (800) 528-3044 Monday through Friday, 8:00 am to 5:00 pm.

INSTALLATION INSTRUCTIONS #619897

CAREFULLY READ INSTRUCTIONS BEFORE STARTING INSTALLATION.

When installing this exhaust system make sure to use proper safety precautions. Use jack stands when working under the vehicle, set parking brake, block tires and use safety glasses and gloves. Allow exhaust to cool before attempting installation. Severe injury or burns could occur if safety measures are not taken.

SUGGESTED TOOLS: 1/2", 9/16" 15mm wrenches & sockets, WD-40, hacksaw, jack stands.

.....
: **Disconnect the negative battery cable before removal of OEM exhaust. This will allow the computer to reset and recognize the**
: **new exhaust. Lay out the exhaust on the floor so it looks like the drawing and compare parts with manual.**
:



1. To remove the stock exhaust remove it from the 2-bolt flange located in front of the stock muffer. Disengage the welded hangers using WD-40 from the OEM rubber grommets. Do not discard, damage stock bolts or remove the rubber grommets as you will re-use them to mount your new system. Now, cut off tailpipe and remove exhaust.



4 Install the overaxle tailpipe #C into the muffer 1½-2". Use clamp #F to secure pipe together. DO NOT TIGHTEN. Insert welded hanger into rubber grommet.



2. Bolt head pipe #A onto your existing stock front pipe using your stock bolts. DO NOT TIGHTEN. Insert welded hangers into rubber grommets.



5 Next, install the exit pipe #D to tailpipe. Use clamp #F to secure. DO NOT TIGHTEN. Insert welded hanger into rubber grommet.



3. Install muffer #B onto head pipe 1½-2" with the louvers facing towards the converter. Muffer inlet is looking into louvers. Use a jack stand to support the muffer. Outlet should be at the 4 o'clock position. Use clamp #F to secure the muffer to the headpipe. DO NOT TIGHTEN.



6 Install stainless steel tip #E. Clamp down. When you have everything in place, firmly tighten all bolts and clamps down securely. Use stainless steel cleaner and a Scotch Brite pad weekly to prevent tip from discoloration.

GIBSON EXHAUST systems are designed on a factory stock vehicle. Any aftermarket products installed could increase the sound levels of this Exhaust. **Make sure there is a 1" clearance from ALL rubber brake lines, shock boots, fuel lines, tires, etc to prevent heat related damage or fire.**